

Pin connections

Pin	Symbol
1	VSS
2	VDD
3	V0
4	D/R
5	R/W
6	E
7-14	DB0-DB7
15	/CS1
16	/RST
17	NC/VEE
18	/CS2
19	LED+
20	LED-

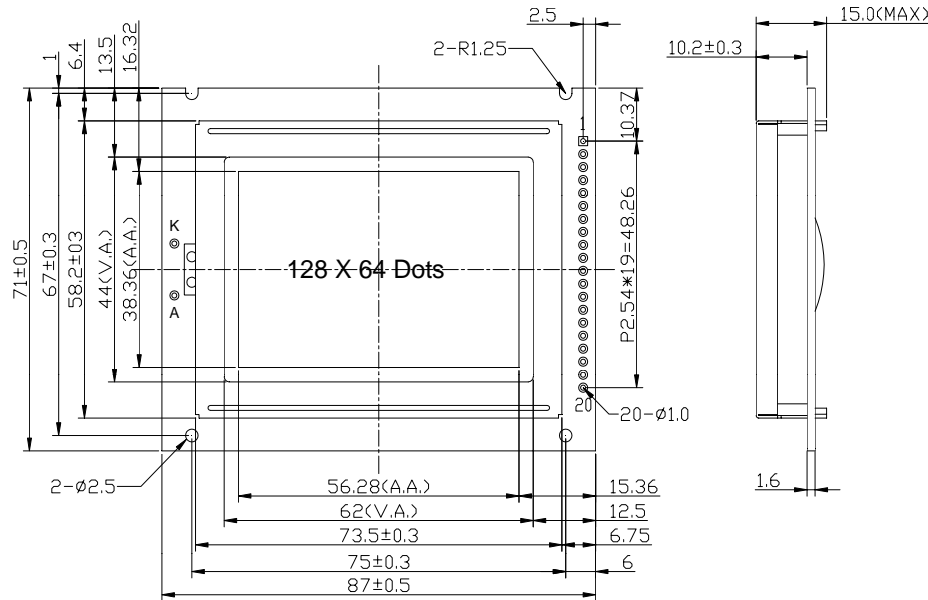

Block diagram

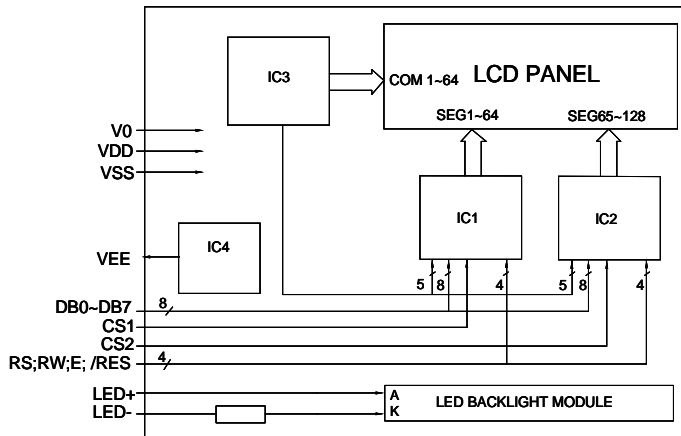

Feature

- 128dots X 64dots matrix.
- Built-in controller (S6B0108)
- Interface with 8-bit ;5V power supply
- 5V;1/64Duty cycle, 1/9Bias.
- Display Mode & Backlight Variations.
- ROHS Compliant

Mechanical thickness

LCD module	T1	T2	Unit
Without or EL	5	10.0	mm
Edge backlight	---	---	mm
Bottom backlight	10.2	15.0	mm

Mechanical data

Item	Standard	Unit
Module size	78.0X70.0	mm
View area	62.0X44.0	mm
Dot size	0.40X0.56	mm
Area size	56.28X38.36	mm

Maximum Absolute Power Ratings

Item	Symbol	Standard			Unit
		Min	Typ	Max	
Input voltage	V _{DD}	-0.3	---	5.5	V
Power supply	V _{in}	-0.3	---	V _{DD}	

Electronical characteristics

Item	Symbol	Condition	Standard			Unit
			Min	Typ	Max	
Operating voltage	V _{DD}	V _{DD} =5.0V	4.5	---	5.5	V
Operating current	I _{DD}	V _{DD} =5.0V	---	7.2	8	mA
Recommended LCD driving voltage for normal temp module	V _{LCD}	T _A =+25	---	8.5	---	V
		T _A =0	---	8.7	---	
		T _A =-20	---	9.1	---	
Backlight voltage	V _{LED}	Y-G	---	4.2	---	V
Backlight current	I _{LED}	V _{LED} =4.2V	---	240	---	mA
Operating temperature	T _o	---	-20	---	70	
Storage temperature	T _S	---	-30	---	80	